

Curved Sign Holder with Acryled



See movie at our website www.mtdisplays.com.tr



Curved Sign Holder with Acryled has both silver & black finish. Curved Sign Holder is suitable to use in hotels, galleries, museums, restaurants, lobby, bars. Available in 8.5" X 11" and 11" X 17" portrait and landscape positions. Special treated acrylic and LED technology illuminates prints homogenous. The edgelit Acryled mounts on Curved Sign Holder both portrait & landscape. Poster placed in position by 2 clear clips on 2 short sides.

All units pass CE/UL PAT test. Packed with quality certificates & 3,5 meter electrical cable. UK and US plugs should be mentioned on order.

Led illumination saves up to 60% energy cost. Heavy base provide stability.

Color options :
Silver-anodized & black

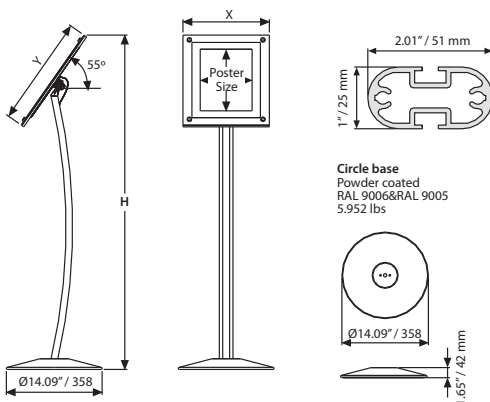

MATERIAL : Silver & Black anodised aluminium							WEIGHT	PACKING SIZE
SILVER	BLACK	EXTERNAL (x-y)	POSTER	COPY	HEIGHT	DESCRIPTION	WITH PACKING	*W X H X D
UCUALN0081	UCUALB0081	12.95" X 410	8.5" X 11"	7.79" X 10.29"	49.21"	Portrait	15.763 lbs	14.37" X 43.70" X 4.02"
					47.83"	Landscape		
UCUALN0017	UCUALB0017	410 X 533 mm	11" X 17"	10.259" X 16.29"	49.21"	Portrait	18.408 lbs	30.87" X 53.15" X 4.33"
					51.30"	Landscape		



*W:Width H: Height D: Depth